

OPzV series is Valve Regulated Lead Acid battery that adopts immobilized GEL and Tubular Plate technology to offer high reliability and performance. The Battery is designed and manufactured according to DIN standards and with die-casting positive grid and patented formula of active material OPzV series exceeds DIN standard values with more than 20 years floating design life at 25 °C ,and It is the best solution for cyclic use under extreme operating conditions.



Specification

Cells Per Unit	1
Voltage Per Unit	2
Nominal Capacity	1500Ah@10hr-rate to 1.80V per cell @25°C
Weight	Approx. 110.0 Kg (Tolerance ±1%)
Internal Resistance	Approx. 0.40 mΩ
Terminal	F10(M8)
Max. Discharge Current	4500A (5 sec)
Design Life	20 years (floating charge)
Maximum Charging Current	300.0 A
Reference Capacity	C24 1639AH C48 1830AH C72 1845AH C100 1870AH C120 1908AH C240 1941AH
Float Charging Voltage	2.25 V~2.30 V @ 25°C Temperature Compensation: -3mV/°C/Cell
Cycle Use Voltage	2.37 V~2.40 V @ 25°C Temperature Compensation: -4mV/°C/Cell
Operating Temperature Range	Discharge: -40°C~60°C Charge: -20°C~50°C Storage: -40°C~60°C
Normal Operating Temperature Range	25°C ±5°C
Self Discharge	GERCH Valve Regulated Lead Acid (VRLA) batteries can be stored for up to 6 months at 25°C and then recharging is recommended. Monthly Self-discharge ratio is less than 2% at 25°C. Please charged batteries before using.
Container Material	A.B.S. UL94-HB, UL94-V0 Optional.

Dimensions

Unit: mm

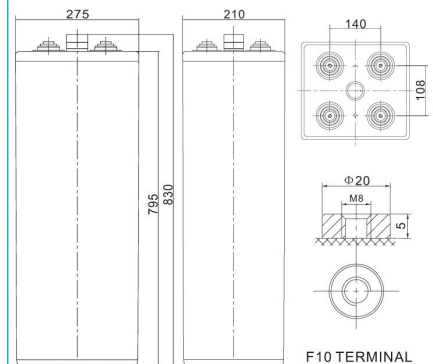

Length	275±1mm (10.8 inches)
Width	210±1mm (8.27 inches)
Height	795±1mm (31.3 inches)
Total Height	830±1mm (32.7 inches)
Torque Value	10~12 N*m

Constant Current Discharge Characteristics :A(25°C)

F.V/ Time	30min	1h	2h	3h	4h	5h	6h	8h	10h	20h
1.90V	738.0	585.0	412.5	312.9	256.5	221.7	199.5	155.7	133.5	70.09
1.87V	825.0	645.0	442.5	331.8	270.8	233.1	211.5	163.0	139.5	73.24
1.83V	945.0	720.0	480.0	353.6	285.0	243.3	219.0	170.2	145.5	76.39
1.80V	1050	780.0	498.0	363.8	290.7	249.0	225.0	174.6	150.0	78.75
1.75V	1170	835.5	520.5	378.3	295.5	255.0	229.5	177.5	153.0	80.33
1.70V	1290	862.5	535.5	385.7	300.7	258.0	232.5	179.0	154.5	81.11
1.65V	1331	916.5	553.5	396.0	305.0	261.0	235.5	180.4	156.0	81.90
1.60V	1388	948.0	574.5	412.5	313.5	265.5	238.5	181.9	157.5	82.69

Constant Power Discharge Characteristics : WPC(25°C)

F.V/ Time	30min	1h	2h	3h	4h	5h	6h	8h	10h	20h
1.90V	1413	1123	797.5	606.0	502.0	436.5	394.5	311.4	272.1	142.8
1.87V	1554	1220	845.7	634.7	529.1	457.5	417.0	324.5	283.7	149.0
1.83V	1741	1330	900.0	667.8	554.8	475.5	430.5	336.1	293.9	154.3
1.80V	1902	1419	930.1	683.0	565.3	486.0	441.0	343.4	301.2	158.1
1.75V	2064	1482	960.3	704.0	572.9	498.0	448.5	347.7	305.6	160.4
1.70V	2213	1497	984.4	716.1	581.9	502.5	453.0	350.7	308.5	161.9
1.65V	2251	1563	1012	731.1	589.4	507.0	457.5	353.6	309.9	162.7
1.60V	2278	1612	1036	755.3	604.5	511.5	460.5	355.0	311.4	163.5

(Note)The above characteristics data are average values obtained within three charge/discharge cycle not the minimum values.

