

OPzS series is flooded Lead Acid battery that adopts Tubular Plate technology to offer high reliability and performance. The Battery is designed and manufactured according to standards and with DIN40736-2/IEC60896-11 positive spine and patent formula of die-casting active material. OPzS series exceeds standard values with more DIN40736-2/IEC60896-11 than 20 years floating design even more suitable for life at 25°C and is cyclic use(PV/solar, traction etc) under extreme operating conditions.

Specification

Cells Per Unit	1
Voltage Per Unit	2
Nominal Capacity	2000Ah@10hr-rate to 1.85V per cell @25°C
Weight	Without Electrolyte 112.8kg/With Electrolyte 153.4kg
Internal Resistance	Approx. 0.17 mΩ
Terminal	F10(M8)
Max. Discharge Current	7500A (5 sec)
Design Life	20 years (floating charge)
Maximum Charging Current	200.0 A
Reference Capacity	C24 2394.0AH C48 2644.8AH C72 2777.0AH C100 2840.7AH C120 2897.5AH C240 2946.0AH
Float Charging Voltage	2.23 V~2.25 V @ 25°C Temperature Compensation: -3mV/°C/Cell
Cycle Use Voltage	2.40 V~2.45 V @ 25°C Temperature Compensation: -4mV/°C/Cell
Operating Temperature Range	Discharge: -15°C~50°C Charge: 0°C~40°C Storage: -15°C~50°C
Normal Operating Temperature Range	25°C ± 5°C
Self Discharge	GERCH Valve Regulated Lead Acid (VRLA) batteries can be stored for up to 6 months at 25°C and then recharging is recommended. Monthly Self-discharge ratio is less than 3.5% at 25°C. Please charged batteries before using.
Container Material	A.B.S. UL94-HB, UL94-V0 Optional.



Dimensions

Unit: mm

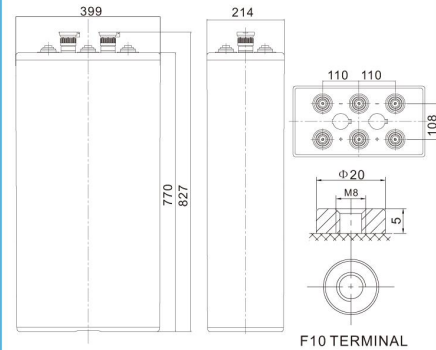

Length	399±1mm (15.7 inches)
Width	214±1mm (8.43 inches)
Height	770±1mm (30.3 inches)
Total Height	827±1mm (32.6 inches)
Torque Value	10~12 N*m

Constant Current Discharge Characteristics :A(25°C)

F.V/ Time	30min	1h	2h	3h	4h	5h	6h	8h	10h	20h
1.90V	1064	843.6	594.8	453.4	359.1	319.2	279.3	218.0	186.9	107.49
1.87V	1190	930.1	638.1	482.7	379.1	337.6	296.1	228.1	195.3	112.3
1.83V	1363	1038	692.2	516.3	399.0	352.8	306.6	238.3	203.7	117.1
1.80V	1514	1125	718.1	531.4	407.0	361.0	315.0	244.4	210.0	120.7
1.75V	1687	1205	750.6	548.4	413.7	367.5	321.3	248.5	214.2	123.1
1.70V	1860	1244	772.2	561.4	420.9	373.2	325.5	250.6	216.3	124.4
1.65V	1919	1322	798.1	575.4	426.9	378.3	329.7	252.6	218.4	125.6
1.60V	2001	1367	828.4	594.7	438.9	386.4	333.9	254.6	220.5	126.8

Constant Power Discharge Characteristics : WPC(25°C)

F.V/ Time	30min	1h	2h	3h	4h	5h	6h	8h	10h	20h
1.90V	2037	1619	1150	881.7	702.8	627.4	552.3	435.9	380.9	219.0
1.87V	2241	1759	1220	932.3	740.8	662.3	583.8	454.3	397.2	228.4
1.83V	2511	1917	1298	985.1	776.7	689.7	602.7	470.5	411.5	236.6
1.80V	2743	2046	1341	1011	791.4	704.6	617.4	480.7	421.7	242.5
1.75V	2976	2137	1385	1035	802.0	714.9	627.9	486.8	427.8	245.9
1.70V	3191	2159	1420	1057	814.7	724.6	634.2	490.9	431.8	248.3
1.65V	3246	2254	1459	1079	825.2	732.6	640.5	495.0	433.9	249.5
1.60V	3285	2324	1493	1105	846.3	745.7	644.7	497.0	435.9	250.6

(Note)The above characteristics data are average values obtained within three charge/discharge cycle not the minimum values.

Discharge Characteristics Curve

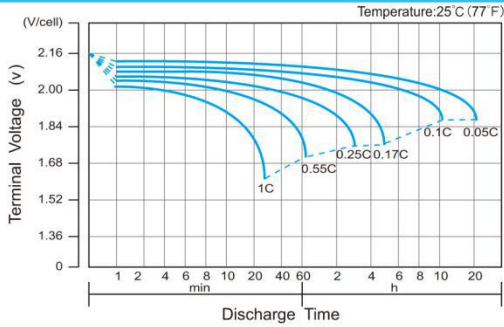

Charge Characteristic Curve for Cycle Use (IU)

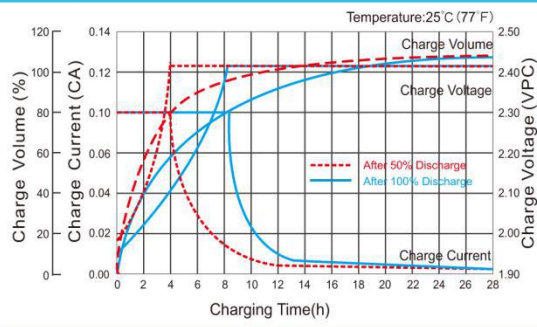

Cycle Life in Relation to Depth of Discharge

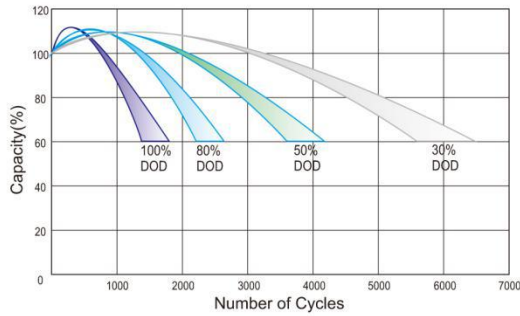

Relationship Between Charging Voltage and Temperature

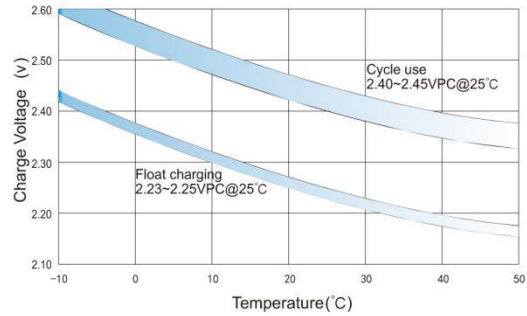

Temperature Effects on Capacity

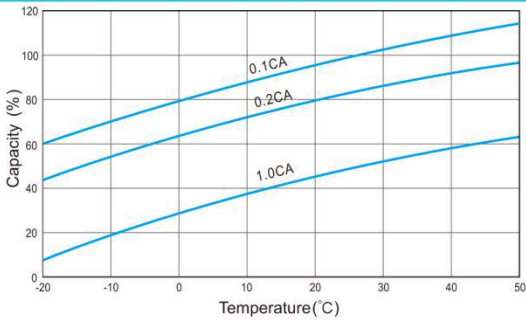

Storage Characteristics

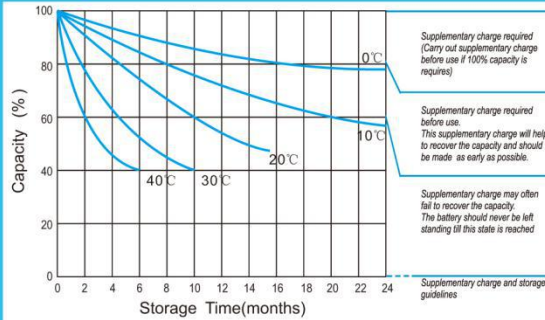

Effect of Temperature on Long Term Life

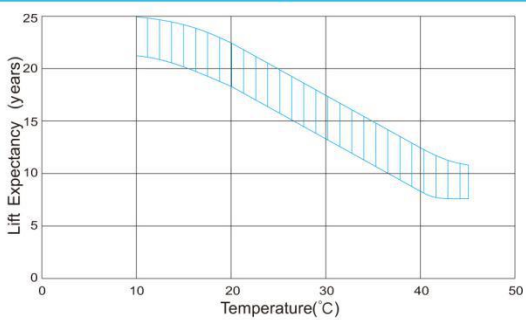

Life Characteristics Of Standby Use

